

**SINGER**  
**52W21,W22**

Form 2844w

(1049)

Printed in U. S. A.

# LIST OF PARTS



MACHINES  
Nos. 52w21 and 52w22

---

\*\* A TRADE MARK OF  
THE SINGER MANUFACTURING COMPANY

# INSTRUCTIONS FOR OILING

---

To ensure easy running and prevent unnecessary wear of the parts which are in movable contact, the machine requires oiling and when in continuous use, "TYPE B" or "TYPE D" OIL, sold only by Singer Sewing Machine Company, should be applied at least twice each day to all oil holes marked "OIL", as instructed in Form 2849w. "TYPE D" OIL is stainless.

## INDEX

---

	PAGE
ACCESSORIES	16
BOBBIN WINDER	16
FOOT LIFTER	17
MACHINE No. 52w21	5
MACHINE No. 52w22	15
MISCELLANEOUS PARTS	18
NUMERICAL LIST OF PARTS	19
THREAD UNWINDER	17

From the library of: Diamond Needle Corp

# INSTRUCTIONS FOR ORDERING

In ordering from this list, use ONLY the PART number in the FIRST column.

The number stamped on a Sewing Machine Part is the number of the Single Part only, except when the part includes Set Screws, Clamping Screws, Studs and Rollers Spun on, Small Wires riveted, or Parts soldered together, etc., which it is necessary to furnish in combination.

Every combination of parts sent out has its specific number which, although not stamped on Parts (except in above case), must be used when ordering the combination.

Each number always indicates the SAME PART in whatever list it appears, or for whatever Machine.

The letters after some of the numbers indicate the style of finish only, as follows:

- A. Hardened, Polished, Nickel Plated and Buffed.
- B. Polished, Nickel Plated and Buffed.
- C. Hardened only.
- D. Polished only.
- E. Soft, not polished.
- F. Hardened and Polished.
- H. Blued.
- J. Nickel Plated only.
- R. Merlized.
- X. Black Oxide, for Iron and Steel.
- XC. Hardened and Black Oxide, for Iron or Steel.
- Y. Black Nickel Plated only.

These letters MUST BE USED when they appear in the list and AFTER the number, as in the list.

In this series

1 to 1500, 200001 to 201500 and 350001 to 351500 are Screw Numbers.  
1501 to 1800, 201501 to 201800 and 351501 to 351800 are Nut Numbers.  
1801 to 2000, 201801 to 202000 and 351801 to 352000 are Roller Numbers.  
2001 to 50000 and 202001 to 350000 are Numbers of Machine Parts.

The figures in the second column refer only to the plate in which the illustration of the part is shown and are NOT TO BE USED in ordering.

Two or more numbers over a cut indicate that the difference between such parts is not visible in an illustration.

Parts marked with an asterisk (\*) are furnished only when repairs are made at the factory.

## LIST OF PARTS COMPLETE FOR

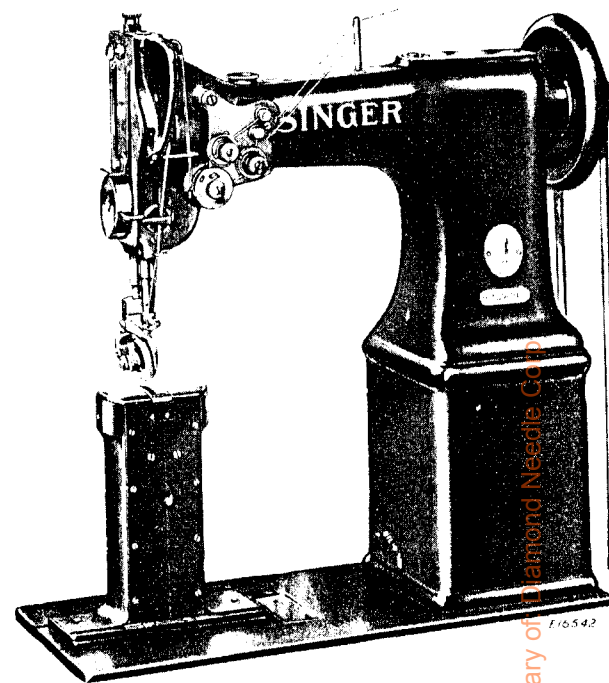

### MACHINE No. 52w21

HIGH SPEED. DROP FEED.

BALL BEARING (No Back) ROLLER PRESSER.

MAXIMUM STITCH 8 TO THE INCH.

FOR LIGHT AND MEDIUM WEIGHT LEATHER

MADE IN GAUGES FROM 1/32 TO 1/4 INCH.

No.	Plate	Name
*234001	-----	Arm with 200368H, 202135 and 234047
*234002	-----	" Base
204235	17624	" " Position Pin (2)
200010E	17624	" " Screw (3)
202005	17624	" " " Washer (3)
202247	17672	" Cap
200278H	17672	" " Screw

From the library of Diamond Needle Corp.

No.	Plate	Name
202248	17672	Arm Cap Screw Washer
10554	17624	" Position Pin (2)
200010E	17624	" Screw (3)
202249	17672	" Shaft with 224392 and 350431E
240802	17672	" " Bushing (back) with 202244
202244	17672	" " " " Oil Packing (wick)
200338C	17672	Arm Shaft Bushing (back) Set Screw
207080	17672	" " " (front) with 202244
202244	17672	" " " " Oil Packing (wick)
200502H	17672	Arm Shaft Bushing (front) Oil Packing Thumb Screw
200338C	17672	Arm Shaft Bushing (front) Set Screw
234003	17624	" " Connection Belt
202635	17624	" " " " Pulley with 200327C, 200602C and two 202253
200602C	17624	Arm Shaft Connection Belt Pulley Position Screw
200327C	17624	Arm Shaft Connection Belt Pulley Set Screw
202253	17624	Arm Shaft Connection Belt Pulley Spring Flange
224392	17672	Arm Shaft Oil Packing (wick)
350431E	17672	" " " " Stop Screw
241561	17672	Balance Wheel (disc) (belt groove 2-3/4 in. diam.) with 200328C and 200335C
200328C	17672	Balance Wheel Position Screw
200335C	17672	" " " " Set Screw
*234004	-----	Bed
202258	17624	" Hinge Connection (2)
200570E	17624	" " " " Screw (4)
203208	17673	Bobbin (2)
235769	17673	" Case Base with 202056, 203211 to 203213 and 203216
203211	17673	Bobbin Case Base Latch
*202056	-----	" " " " Pin
203212	17673	" " " " Plunger
203213	17673	" " " " Spring
241676	17673	" " Cap with 200594C, 200984C, 235771, 241674, 241675 and two 350405C
234079	17680	Bobbin Case Lever
234065	17680	" " " " Driving Block
200076D	17680	" " " " " Screw
201272C	17680	" " " " Hinge Screw
241674	17673	" " " " Oiling Felt
241675	17673	" " " " Retainer
350405C	17673	" " " " " Screw
235771	17673	" " " " Tension Spring
200984C	17673	" " " " " Regulating Screw
200594C	17673	Bobbin Case Tension Spring Screw
203216	17673	" " " " Washer (cloth)
241677	17673	Bobbin Case complete, Nos. 235769 and 241676

No.	Plate	Name
241753	17671	Face Plate with 201650H and 350432XC
202135	17671	" " Position Pin
200462H	17671	" " Thumb Screw
234010	17625	Feed Bar
200641C	17625	" " Hinge Screw (driving)
201518E	17625	" " " " Nut
202276	17625	" " Slide Block
234084	17625	" " " " Crank with 200038C
234011	17625	" " " " " 234084 with 200205F, 201518E and 202276
200038C	17625	Feed Bar Slide Block Crank Pinch Screw
200205F	17625	" " " " " Hinge Screw
201518E	17625	" " " " " " Nut
212777	17679	" Dog, for 234228 and 234229
212875	17679	" " " 234273
212877	17679	" " " 234268
234252	17679	" " " 234269
212789	17679	" " " 234270
212791	17679	" " " 234271
212793	17679	" " " 234272
234012	17679	" " Lever with 200098E
200263D	17679	" " " Hinge Screw
201528D	17679	" " " " " Nut
234066	17679	" " " Post
234067	17679	" " " " 234066 with 200909E, 201525E, 203610, 203624, 234012 and two 200098F
200024C	17679	Feed Dog Lever Post Screw (4)
203637	17679	" " " " " Washer (4)
203624	17679	" " " Retainer Washer
200098F	17679	" " " " " Screw
203610	17679	" " " Slide Block
200909E	17679	" " " " " Hinge Screw
201525E	17679	" " " " " " "
		Nut
200098E	17679	Feed Dog Screw
234015	17624	" Driving Connection with 200049E and 202277
202298	17625	Feed Driving Connection Crank with 200038C
200038C	17625	Feed Driving Connection Crank Pinch Screw
200545C	17624	Feed Driving Connection Hinge Screw
201518E	17624	" " " " " Nut
202277	17624	" " " " " Oil Packing (wick)
200049E	17624	Feed Driving Connection Pinch Screw
202300	17624	" " " Eccentric Regulating Bracket
203098	17624	Feed Driving Eccentric Regulating Bracket 202300 with 202635, two each 201014C and 201525E
201014C	17624	Feed Driving Eccentric Regulating Bracket Hinge Screw
201525E	17624	Feed Driving Eccentric Regulating Bracket Hinge Screw Nut

No.	Plate	Name
202301	17624	Feed Driving Eccentric Regulating Bracket Plunger
202595	17624	Feed Driving Eccentric Regulating Bracket Plunger Spring
200607C	17624	Feed Driving Eccentric Regulating Bracket Plunger Spring Stop Screw
201014C	17624	Feed Driving Eccentric Regulating Bracket Stop Screw
201525E	17624	Feed Driving Eccentric Regulating Bracket Stop Screw Nut
200429F	17624	Feed Driving Eccentric Regulating Screw
200383C	17624	Feed Driving Eccentric Regulating Screw Check Screw
202303	17625	Feed Driving Rock Shaft
234016	17625	" " " " 202303 with 200641C, 201518E and 234010
202305	17625	Feed Driving Rock Shaft Center (2)
200043C	17625	" " " " " Set Screw (2)
234017	17624	Feed Lifting Connection with 200049E and 202277
202307	17672	Feed Lifting Connection Eccentric with 200382C and 200437C
200437C	17672	Feed Lifting Connection Eccentric Position Screw
200382C	17672	Feed Lifting Connection Eccentric Set Screw
200545C	17624	Feed Lifting Connection Hinge Screw
201518E	17624	" " " " " Nut
202277	17624	" " " " Oil Packing (wick)
200049E	17624	Feed Lifting Connection Pinch Screw
234018	17625	" " Rock Shaft
202305	17625	" " " " Center (2)
200043C	17625	" " " " " Set Screw (2)
202310	17672	Feed Regulating Spindle with 202311, 202443 and 202619
*202311	-----	Feed Regulating Spindle Head
202443	17672	" " " " Pin
202619	17672	" " " " Position Pin
203061	17671	Foot Lifter Lifting Lever
200242H	17671	" " " " Hinge Screw
234019	17671	" " " " Rod with 202302
202302	17671	Foot Lifter Lifting Lever Rod Cotter Pin
203058	17671	Foot Lifter Lifting Lever Rod Coupling with 200530C
200530C	17671	Foot Lifter Lifting Lever Rod Coupling Set Screw
233361	17671	Foot Lifter Lifting Lever Spring
200273D	17671	" " " " " Screw
233390	17671	" " " " Washer

No.	Plate	Name
*234135	17673	Hook (sewing)
234194	17673	" 234135 with 203525 and two 201253F
234205	17673	Hook and Bobbin Case complete, Nos. 234194 and 241677
234088	17680	Hook Bevel Gear Socket, 14 teeth
234024	17680	" " " " Friction Washer
200555H	17680	" " " " Screw
241551	17675	" " Pinion, 28 teeth, with two 200378C (2)
200378C	17675	Hook Bevel Pinion Set Screw
234026	17675	" Driving Shaft
202321	17675	" " " Bushing (3)
200346C	17675	" " " " Set Screw (3)
234027	17675	" " " Collar with two 200378C (2)
200378C	17675	Hook Driving Shaft Collar Set Screw
234028	17675	" " " Connection Belt
201254C	17675	Pulley with 202253 and two 201254C Hook Driving Shaft Connection Belt Pulley Set Screw
202253	17675	Hook Driving Shaft Connection Belt Pulley Spring Flange
224392	17675	Hook Driving Shaft Oil Packing (wick) (3)
203525	17673	Hook Gib
201253F	17673	" " Screw
234069	17680	" Post (inside or outside)
234206	17680	" " 234069 with 200555H, 201272C, 202299, 234024, 234065, 234079, 234088, 234205, 234209 and two 200076D
234207	17680	Hook Post 234206 with 203630, 221215, 234073 and eight 200583H
234208	17680	Hook Post 234206 with 221215, 234074, 234083 and eight 200583H
200159F	17680	Hook Post Clamping Screw
203630	17680	" " Cover Plate (back) (inside)
234083	17680	" " " " " (outside)
234073	17680	" " " " " (front) (inside)
234074	17680	" " " " " (outside)
200583H	17680	" " " " " Screw
202299	17680	" " Oil Packing (wick)
200008C	17680	" " Screw (4)
203637	17680	" " Washer (4)
221215	17680	" " Slide
234209	17673	" Washer
234210	-----	Hook Post Combination (inside and outside) complete, Nos. 234067, 234207, 234208 and two 200159F
231390	17677	Needle Bar (hollow)
235871	17677	" " Bushing (lower)
235872	17677	" " " (upper)
200352C	17677	" " " Set Screw (2)
238251	17677	" " Connecting Link
264718	17677	" " " " Oil Guard
200161D	17677	" " " " " Screw

No.	Plate	Name
202333	17677	Needle Bar Connecting Link Stud with 202254
202254	17677	Needle Bar Connecting Link Stud Oil Packing (wick)
200374C	17677	Needle Bar Connecting Link Stud Set Screw
200383C	17677	Needle Bar Connecting Link Stud Set Screw
264714	17677	Needle Bar Connecting Stud with 200072C and 202277
202277	17677	Needle Bar Connecting Stud Oil Packing (wick)
200072C	17677	Needle Bar Connecting Stud Pinch Screw
202692	17677	Needle Bar Crank with 200335C, 200374C, 200383C, 200428C and 202333
234211	17677	Needle Bar Crank 202692 with 202399, 202400, 238251, 247570 and 264714
203172	17677	Needle Bar Crank Friction Washer
200428C	17677	" " " Position Screw
200335C	17677	" " " Set Screw
234212	17677	" Holder, needles .084 in. apart and must be set diagonally for gauges 1/32 and 3/64 in., with 201030F and two 200141F
234213	17677	Needle Holder, needles 3/32 in. apart and must be set diagonally for 1/16 in. gauge, with 201030F and two 200141F
231398	17677	Needle Holder, in gauges from 3/32 to 1/4 in., in steps of 1/32 in., with 201030F and two 200141F
201030F	17677	Needle Holder Screw
200141F	17677	" Set Screw
241535	17678	Presser Bar Bushing
200352C	17678	" " " Set Screw
202554	17678	" " Lifter
200653	17678	" " Hinge Screw
244006	17678	" " Lifting Releasing Lever Bracket
200260D	17678	Presser Bar Lifting Releasing Lever Bracket Guide Screw
206608	17678	Presser Bar Lifting Releasing Lever Bracket Spring (spiral)
235901	17678	Presser Bar Position Guide with 200054E
200054E	17678	Presser Bar Position Guide Pinch Screw
236089	17678	Presser Bar Spring
234044	17678	Presser Bar Spring Stop Rod
200492H	17678	" " Thumb Screw (pressure regulating)
200475H	17678	Presser Bar Thumb Screw Thumb Set Screw
202355	17678	Presser Bar Thumb Screw Thumb Set Screw Packing (brass)

No.	Plate	Name
351856	17678	Roller Presser, 1-1/4 in. diam., 3/16 in. face (fine) with 1528J, 1766C, 50553C and twenty-four 16232
234214	17678	Roller Presser (no back) complete, Nos. 234215, 234217, 350473E and 351856
234215	17678	Roller Presser Arm
235087	17678	Roller Presser Arm Bracket (swing)
235088	17678	" " " " Position Collar with 200362C
200117F	17678	Roller Presser Arm Bracket Position Collar Position Screw
200362C	17678	Roller Presser Arm Bracket Position Collar Set Screw
202558	17678	Roller Presser Arm Bracket Spring
229370	17678	" " " " " Stop and Back Needle Guard Holder
229371	17678	Roller Presser Arm Bracket Spring Stop and Back Needle Guard Holder 229370 with 200350H, 201317F and 226220
200350H	17678	Roller Presser Arm Bracket Spring Stop and Back Needle Guard Holder Adjusting Screw
200141F	17678	Roller Presser Arm Bracket Spring Stop Screw
200096D	17678	Roller Presser Arm Screw, for gauges 1/32, 3/64 and 1/16 inch
200082D	17678	Roller Presser Arm Screw, for gauges 3/32 and 1/8 inch
200077D	17678	Roller Presser Arm Screw, for gauges 5/32, 3/16 and 7/32 inch
200064D	17678	Roller Presser Arm Screw, for 1/4 in. gauge
236645	17678	Roller Presser Arm Shim, .024 in. thick
202760	17678	" " " " 1/16 in. thick
229744	17678	" " " " 1/64 in. thick
229745	17678	" " " " 1/32 in. thick
16232	17678	" " Ball, 3/32 in. diameter
1766C	17678	" " " Cone
202557	17678	" " Bar
50553C	17678	" " Hinge Screw
1528J	17678	" " " " Nut
229328	17678	" " Needle Guard (back), in gauges 1/32, 3/64 and 1/16 inch
235074	-----	Roller Presser Needle Guard (back), in 3/32 in. gauge, for No. 9 needle
229330	17678	Roller Presser Needle Guard (back), in 3/32 in. gauge, for No. 13 needle
235075	-----	Roller Presser Needle Guard (back), in 1/8 in. gauge, for No. 9 needle
229331	17678	Roller Presser Needle Guard (back), in 1/8 in. gauge, for No. 13 needle
235076	-----	Roller Presser Needle Guard (back), in 5/32 in. gauge, for No. 9 needle
229332	17678	Roller Presser Needle Guard (back), in 5/32 in. gauge, for No. 13 needle

No.	Plate	Name
229347	17678	Roller Presser Needle Guard (back), in 3/16 in. gauge, with 350061F
229334	17678	Roller Presser Needle Guard (back), in 7/32 in. gauge, with 350061F
229335	17678	Roller Presser Needle Guard (back), in 1/4 in. gauge, with 350061F
201317F	17678	Roller Presser Needle Guard (back) Clamp Screw
226220	17678	Roller Presser Needle Guard (back) Clamp Screw Washer
350061F	17678	Roller Presser Needle Guard (back) Screw
234216	17678	Roller Presser Needle Guard (front), for gauges 1/32, 3/64 and 1/16 inch
201071F	17678	Roller Presser Needle Guard (front) Screw
62853	17678	Roller Presser Ratchet Spring Stop
241936	17678	" " " " " Bracket
234217	17678	Roller Presser Ratchet Spring Stop Bracket 241936 with 665J and 62853
350473E	17678	Roller Presser Ratchet Spring Stop Bracket Screw
665J	17678	Roller Presser Ratchet Spring Stop Screw
234218	17678	Roller Presser and Bar complete, in 1/32 in. gauge, Nos. 200096D, 200117F, 201071F, 202557, 202558, 229328, 229371, 229744, 234214, 234216, 235087, 235088 and two 200141F
234219	17678	Roller Presser and Bar complete, in 3/64 in. gauge, Nos. 200096D, 200117F, 201071F, 202557, 202558, 229328, 229371, 234214, 234216, 235087, 235088, 236645 and two 200141F
234220	17678	Roller Presser and Bar complete, in 1/16 in. gauge, Nos. 200096D, 200117F, 201071F, 202557, 202558, 229328, 229371, 229745, 234214, 234216, 235087, 235088 and two 200141F
234221	17678	Roller Presser and Bar complete, in 3/32 in. gauge, Nos. 200082D, 200117F, 202557, 202558, 229330, 229371, 229744, 229745, 234214, 235087, 235088 and two 200141F
234222	17678	Roller Presser and Bar complete, in 1/8 in. gauge, Nos. 200082D, 200117F, 202557, 202558, 202760, 229331, 229371, 234214, 235087, 235088 and two 200141F
234223	17678	Roller Presser and Bar complete, in 5/32 in. gauge, Nos. 200077D, 200117F, 202557, 202558, 202760, 229332, 229371, 229744, 234214, 235087, 235088 and two 200141F

No.	Plate	Name
234224	17678	Roller Presser and Bar complete, in 3/16 in. gauge, Nos. 200077D, 200117F, 202557, 202558, 202760, 229347, 229371, 229745, 234214, 235087, 235088 and two 200141F
234225	17678	Roller Presser and Bar complete, in 7/32 in. gauge, Nos. 200077D, 200117F, 202557, 202558, 202760, 229334, 229371, 229744, 229745, 234214, 235087, 235088 and two 200141F
234226	17678	Roller Presser and Bar complete, in 1/4 in. gauge, Nos. 200064D, 200117F, 202557, 202558, 229335, 229371, 234214, 235087, 235088, two each 200141F and 202760
247570	17677	Take-up Lever
202399	17677	" " " " Driving Stud with 202277
202277	17677	" " " " Oil Packing (wick)
202400	17677	Take-up Lever Hinge Stud with 202423
202423	17677	" " " " Oil Packing (wick)
200383C	17677	Take-up Lever Hinge Stud Set Screw
202401	17678	" " " " Oiling Felt
200132E	17678	" " " " Screw
234086	17676	Tension Bracket with two each 200397H, 201224B and 236060
200159F	17676	Tension Bracket Screw
234047	17676	" " " " Socket
200368H	17676	" " " " Set Screw
236098	17676	" " " " Thread Guide (double)
200174H	17676	" " " " Screw
234227	17676	Tension Bracket complete, Nos. 200174H, 200978H, 201199F, 223703, 223706, 234086, 236098, 237174, two each 200309E, 204059, 204271, 223438, 223704, three 201572H and four 244048
244048	17676	Tension Disc
236060	17676	" " " " Position Pin
223703	17676	" " " " Release Lever
235072	17678	" " " " Rod
200309E	17676	" " " " Screw
223704	17676	" " " " Plunger
204271	17676	" " " " Washer
223438	17676	" " " " Spring
201224B	17676	" " " " Stud
201572H	17676	" " " " Thumb Nut
223706	17676	Thread Controller Disc
200978H	17678	" " " " Screw
237174	17676	" " " " Spring
241360	17676	" " " " Stop
200132E	17676	" " " " Screw
201199F	17676	" " " " Stud with 204925
200061C	17676	" " " " Set Screw
201572H	17676	" " " " Thumb Nut
204925	17676	" " " " Washer
202414	17676	" " " " Guide

From the City of Diamond Needle Corp



No.	Plate	Name
202417	17676	Thread Guide
203313	17672	" " "
200355H	17676	" " Set Screw
200397H	17676	" " " "
241755	17671	" Lubricator Oil Pad (felt)
241756	17671	" " " " Holder
240439	17671	" " " " Retainer
241758	17671	" " " Reservoir
241759	17671	" " " Wick
350432XC	17671	" " Screw
201650H	17671	" " Nut
214838	17671	" " Washer
241760	17671	Thread Lubricator complete, Nos. 214838, 240439, 241755, 241756, 241758 and 241759
202091	17676	Thread Retainer Sleeve
202092	17676	" " Spring
204058	17676	" " Stud
200397H	17676	" " " Set Screw
204059	17676	Thread Retainer complete, Nos. 202091, 202092 and 204058
234228	17679	Throat Plate, 53 needle hole, needles .084 in. apart, for needle sizes 12 and 13, in gauges 1/32 and 3/64 in., for 212777
234229	17679	Throat Plate, 53 needle hole, needles 3/32 in. apart, for needle sizes 12 and 13, in 1/16 in. gauge, for 212777
234273	17679	Throat Plate, 50 needle hole, for needle sizes 14 and 15, in 3/32 in. gauge, for 212875
✓234268	17679	Throat Plate, 50 needle hole, for needle sizes 14 and 15, in 1/8 in. gauge, for 212877
234269	17679	Throat Plate, 50 needle hole, for needle sizes 14 and 15, in 5/32 in. gauge, for 234252
234270	17679	Throat Plate, 50 needle hole, for needle sizes 14 and 15, in 3/16 in. gauge, for 212789
234271	17679	Throat Plate, 50 needle hole, for needle sizes 14 and 15, in 7/32 in. gauge, for 212791
234272	17679	Throat Plate, 50 needle hole, for needle sizes 14 and 15, in 1/4 in. gauge, for 212793
200577AL	17679	Throat Plate Screw (2)

## MACHINE No. 52w22

HIGH SPEED. DROP FEED. LONG TAKE-UP.

BALL BEARING (No Back) ROLLER PRESSER.

MAXIMUM STITCH 8 TO THE INCH.

FOR MEDIUM AND HEAVY WEIGHT LEATHER

MADE IN GAUGES FROM 1/32 TO 1/4 INCH.

Same as Machine No. 52w21 with the following exceptions:

No.	Plate	Name
*221214	17674	Hook (sewing)
221216	17674	" 221214 with 201253F, 201376F and 203251
264152	17674	Hook and Bobbin Case complete, Nos. 221216 and 241677
203251	17674	Hook Gib
201376F	17674	" " Hinge Screw
234235	17681	" Post 234069 with 200555H, 201272C, 202299, 234024, 234065, 234079, 234088, 234238, 264152 and two 200076D
234236	17681	Hook Post 234235 with 203630, 221215, 234073 and eight 200583H
234237	17681	Hook Post 234235 with 221215, 234074, 234083 and eight 200583H
234238	17674	Hook Washer
234239	-----	Hook Post Combination (inside and outside) complete, Nos. 234067, 234236, 234237 and two 200159F
237569	17682	Needle Bar Crank 202692 with 202399, 202400, 234144, 238251 and 264714
234144	17682	Take-up Lever

SINGER Needles should be used in SINGER Machines. These Needles and their Containers are marked with the Company's Trade Mark "SIMANCO. \*\*\*" 1

Needles in Containers marked "FOR SINGER MACHINES" are NOT **SINGER** made needles. 2

From the library of: SINGER Sewing Machine Corp.

## ACCESSORIES

No.	Plate	Name
203208	17673	Bobbin (10)
228476	17620	Screw Driver (Bobbin Case)
4822	17678	Roller Presser Hinge Screw Nut Wrench
128x4	-----	Needles, six each, sizes 12 and 14
228213	17657	Drip Pan with four 3/4 in. wire nails
41400	17620	Machine Rest Pin (wood)
120342	17620	Oiler (copper plated) with 120343
120343	17620	" Spout (3-1/2 in. long)
225498	17620	Screw Driver (7-1/4 in. long)
225554	17620	Wrench (steel)

## BOBBIN WINDER

(SWINGING AUTOMATIC, RIGHT HAND)

FOR 5/16 INCH ROUND BELT DRIVE

259428	16615	Brake (leather)
259429	16615	" Clamp
200113F	16615	" " Screw
225453	16615	Frame with 202277 and 259660
225454	16615	" Hinge Pin
202277	16615	" Oil Packing (wick)
259660	16615	" " Well Washer
225455	16615	" Spring
225456	16615	" " Plunger
225368	16615	Pulley with 200380C
200380C	16615	" Set Screw
225381	16615	Spindle
225444	16615	Stop Latch
200056E	16615	" " Screw
225458	16615	" " Thumb Lever
225459	16615	" " " " Hinge Stud
225459	16615	" " " " Joint Stud
202478	16615	" " Trip Lever
200299H	16615	" " " " Hinge Screw
225461	16615	Tension Bracket with 201499H
200082D	16615	" " Screw
228026	16615	" " " Washer
2102	16615	" Disc
13710	16615	" Spring
201499H	16615	" Stud
201572H	16615	" " Thumb Nut
225462	16615	Bobbin Winder Tension Bracket complete, Nos. 13710, 201572H, 225461 and two 2102
259430	16615	Bobbin Winder and Tension Bracket Base

No.	Plate	Name
259431	16615	Universal Bobbin Winder complete, Nos. 200056E, 200082D, 200113F, 200299H, 202478, 225368, 225381, 225444, 225453 to 225456, 225458, 225462, 228026, 259428 to 259430, two each 225459 and wood screws 3/4 in., No. 12, R.H.B.

## FOOT LIFTER

227952	17620	Foot Lifter Lever (left or right) with 227954
227678	17620	Foot Lifter Lever Chain, 48 in. long, with 202784
227954	17620	Foot Lifter Lever Chain Hook (lower)
202784	17620	" " " " " (upper)
225016	17620	" " " Hinge Pin
227939	17620	" " " Stand with two wood screws 1 in., No. 12
227955	17620	Foot Lifter Lever (left or right) complete, Nos. 225016, 227678, 227939 and 227952

(Other Foot Lifter parts are listed with parts of machine head)

## THREAD UNWINDER

FOR THREE SPOOLS

225259	16257	Spool Rest (for one spool) (flat) with 201018C
225257	16257	Spool Rest (for two spools) (flat) with 201018C
150203	16257	Spool Rest Cushion (felt)
225388	16257	" " Rod
200383C	16257	" " " Set Screw
201018C	16257	" " " Set Screw
259658	16257	" Stand with 200383C
225391	16257	Thread Guide
201696H	16257	" " Lock Nut
225326	16257	" " Position Cup
225324	16257	" " Rod with 208AL and 225322
208AL	16257	" " " Screw
225322	16257	" " " Washer
259143	16257	Thread Unwinder (for three spools) complete, Nos. 201696H, 225257, 225259, 225324, 225326, 225388, 259658, three each 150203, 225391 and wood screws 7/8 in., No. 12

From the library of: Diamond Speede Co.

## MISCELLANEOUS PARTS

USED IN CONJUNCTION WITH THREAD UNWINDER

No.	Plate	Name
60913	16257	Spool Weight with 60914
60914	16257	" " Center Pin
225377	16257	" Wire, for small spools
27739	16257	Thread Cone (wood)
225390	16257	" " Holder

SINGER Needles should be used  
in SINGER Machines.  
These Needles and their Containers  
are marked with the  
Company's Trade Mark "SIMANCO.\*\*\*" 1

Needles in Containers marked  
"FOR SINGER MACHINES"  
are NOT **SINGER** made needles. 2

16257 - 1/6

259143

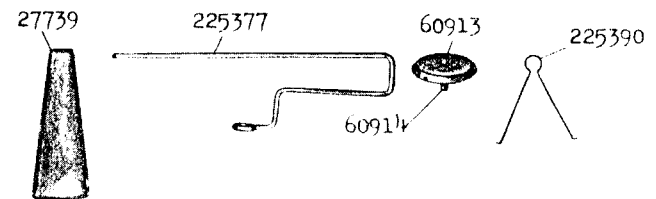
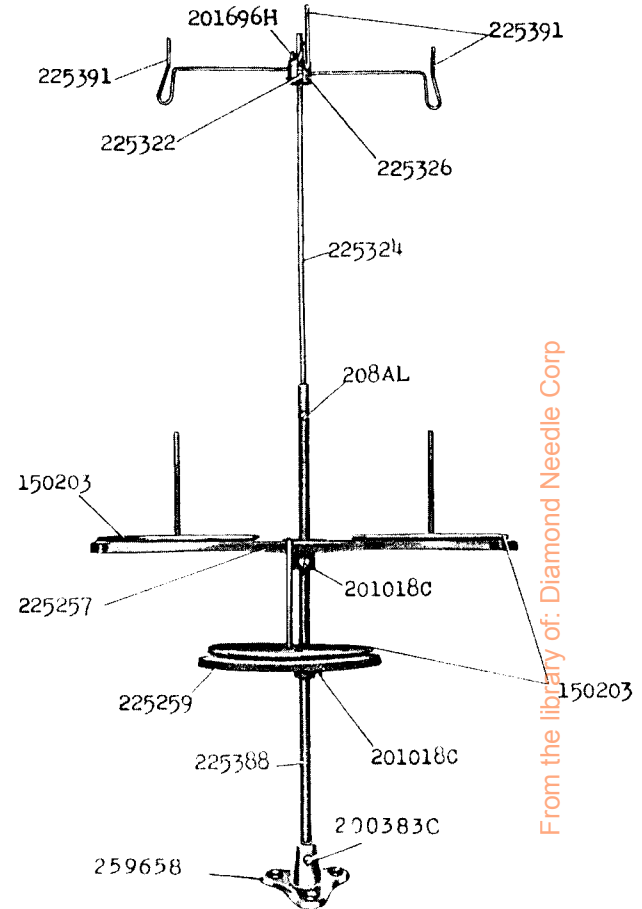

16615 - 1/2

259431

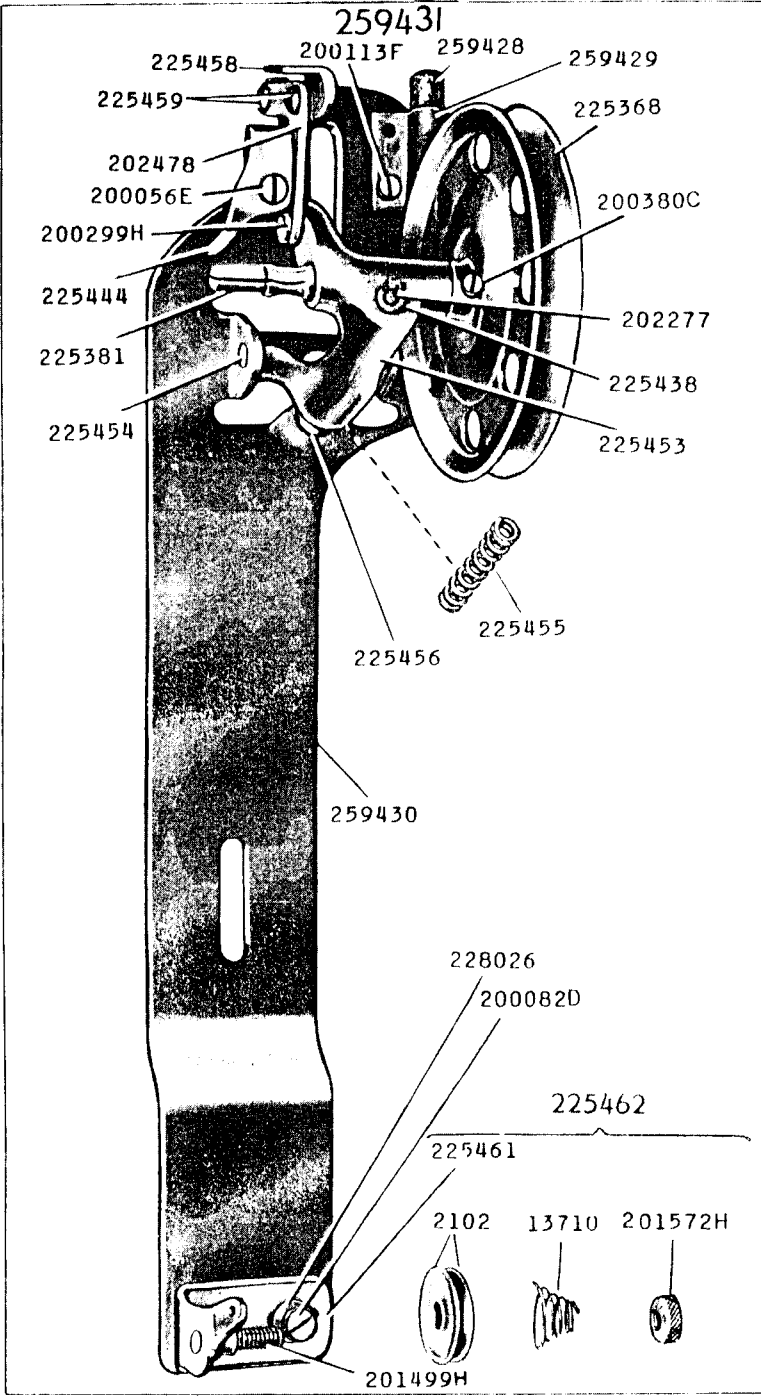

17620 - 1/3

227955

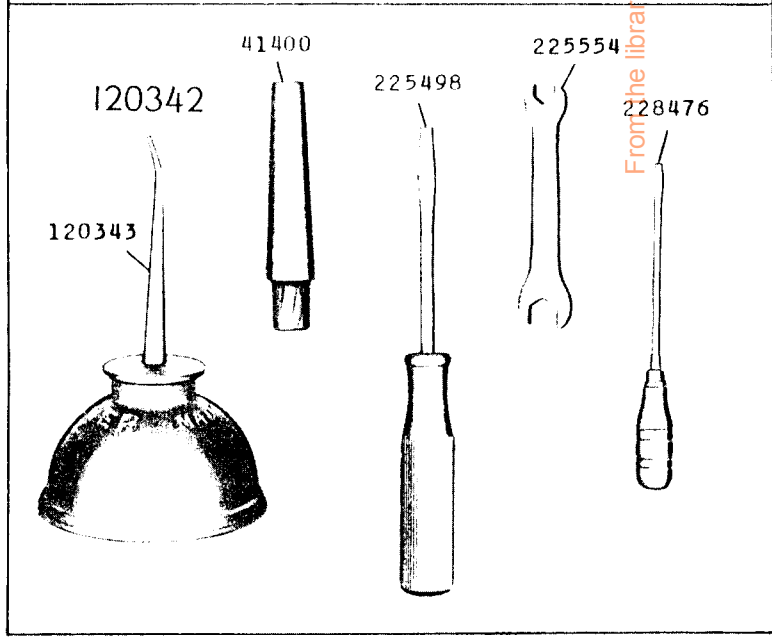
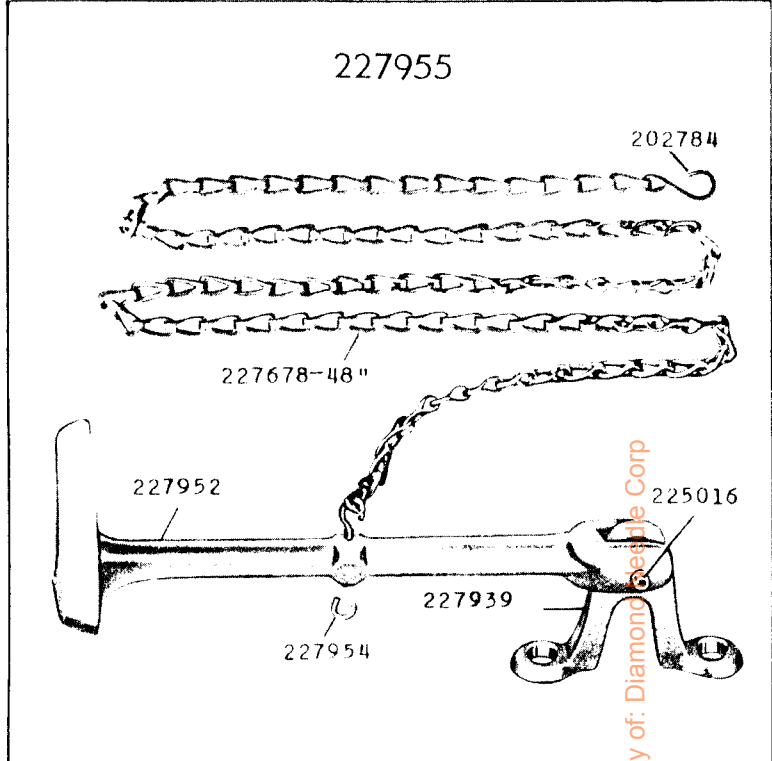

From the library of: Diamond Beetle Corp

17624 - 1/3

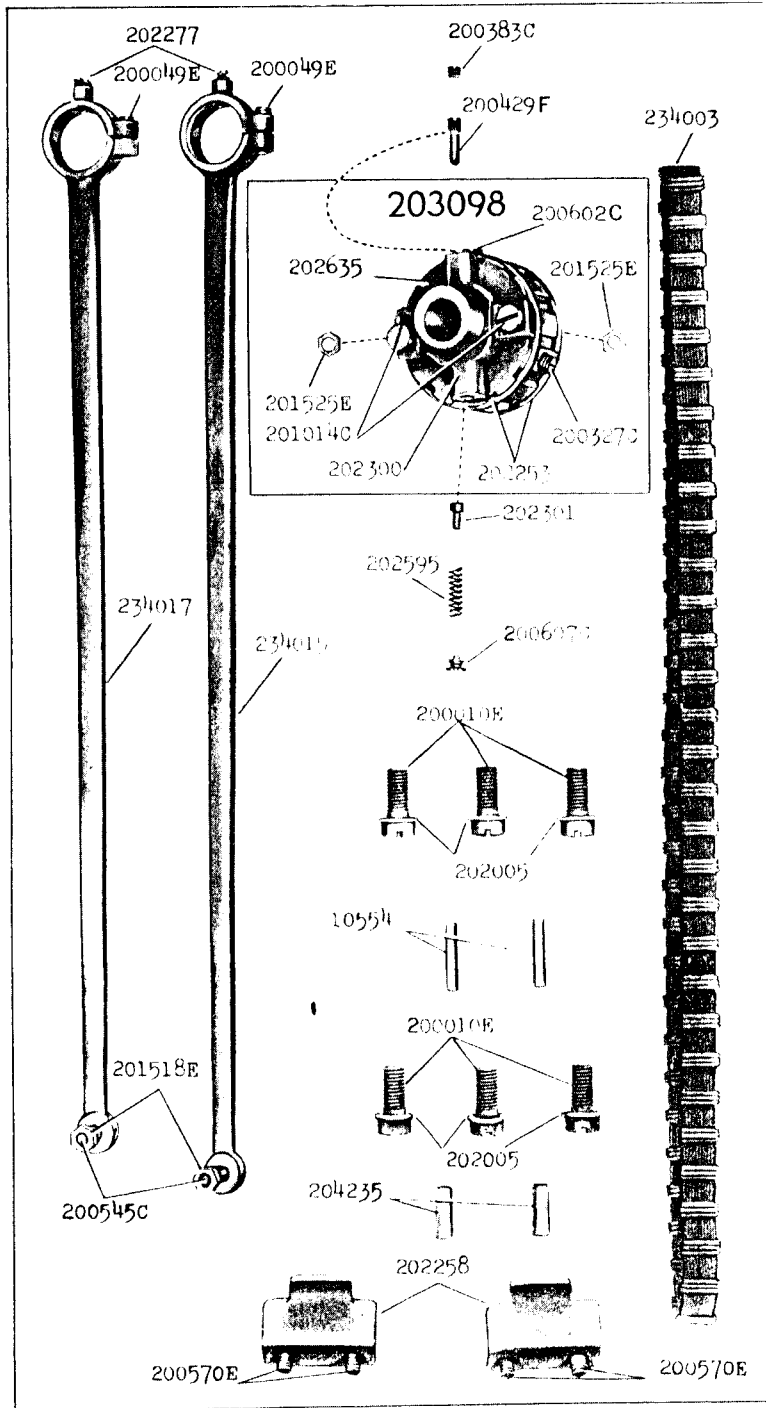

17625 - 1/2

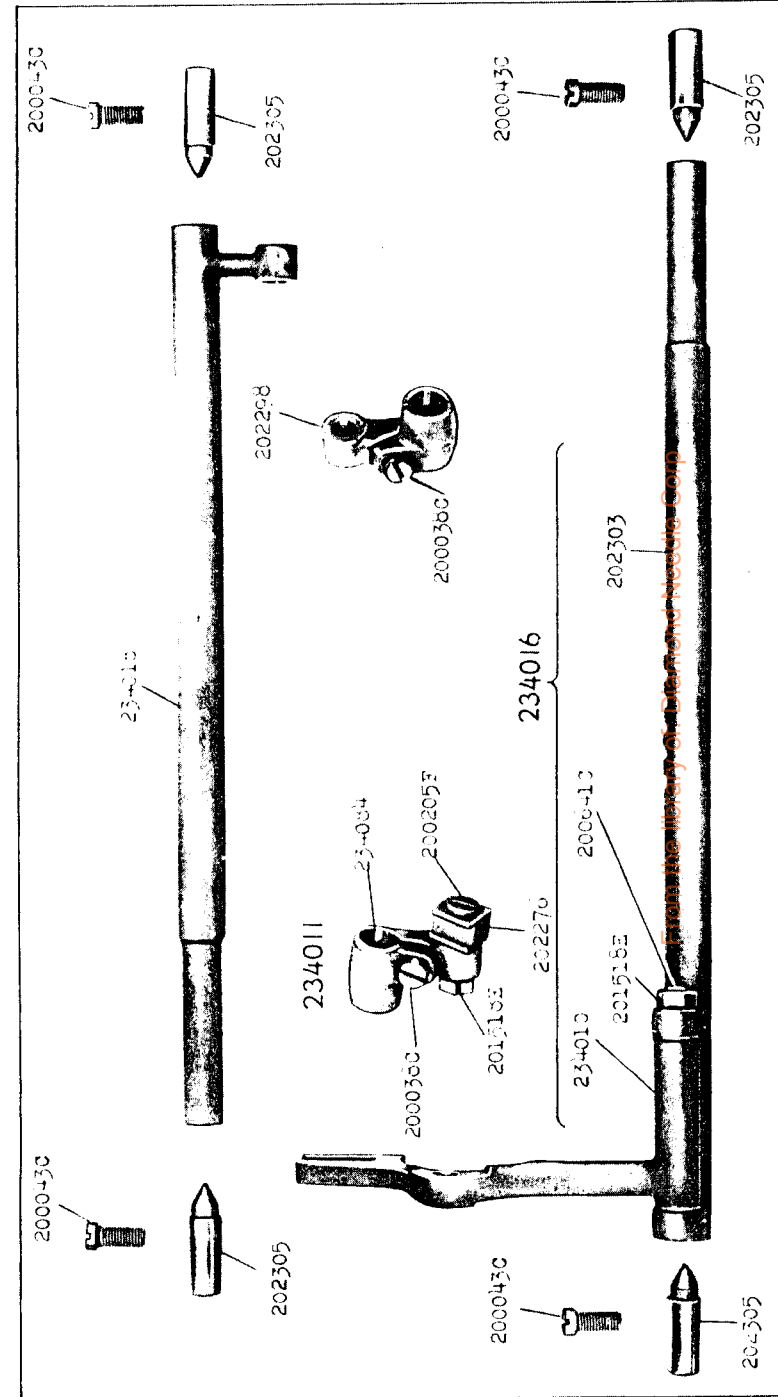

17657 - 3/8

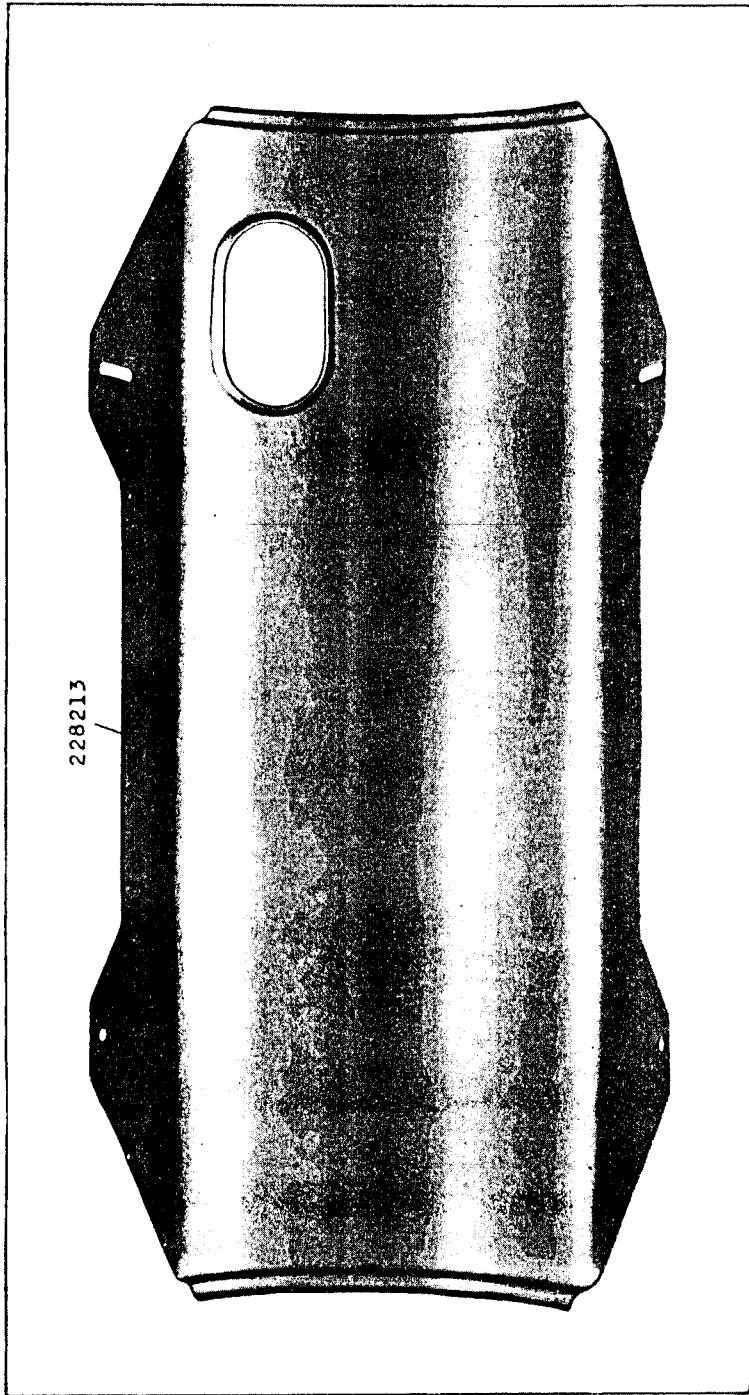

17671 - 3/8

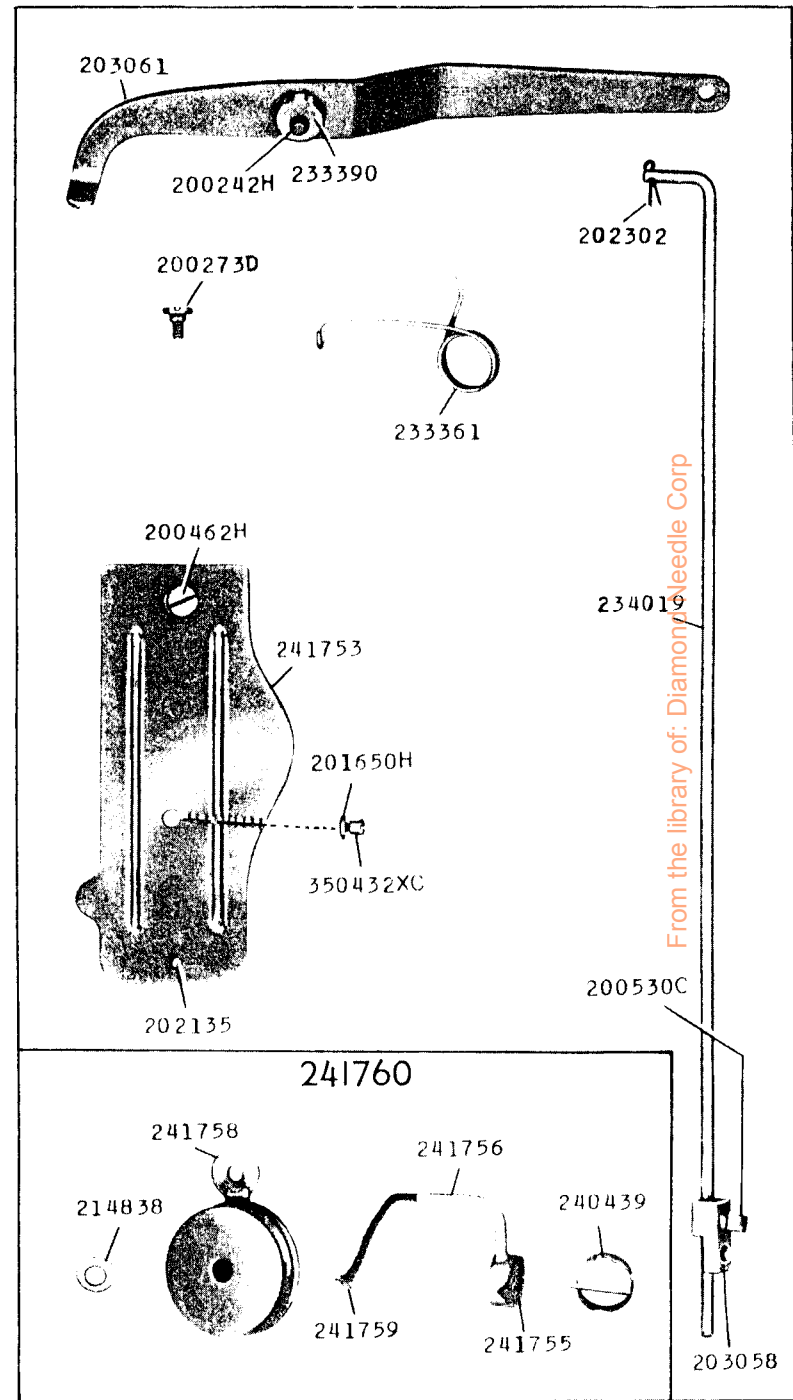



17672 - 1/3

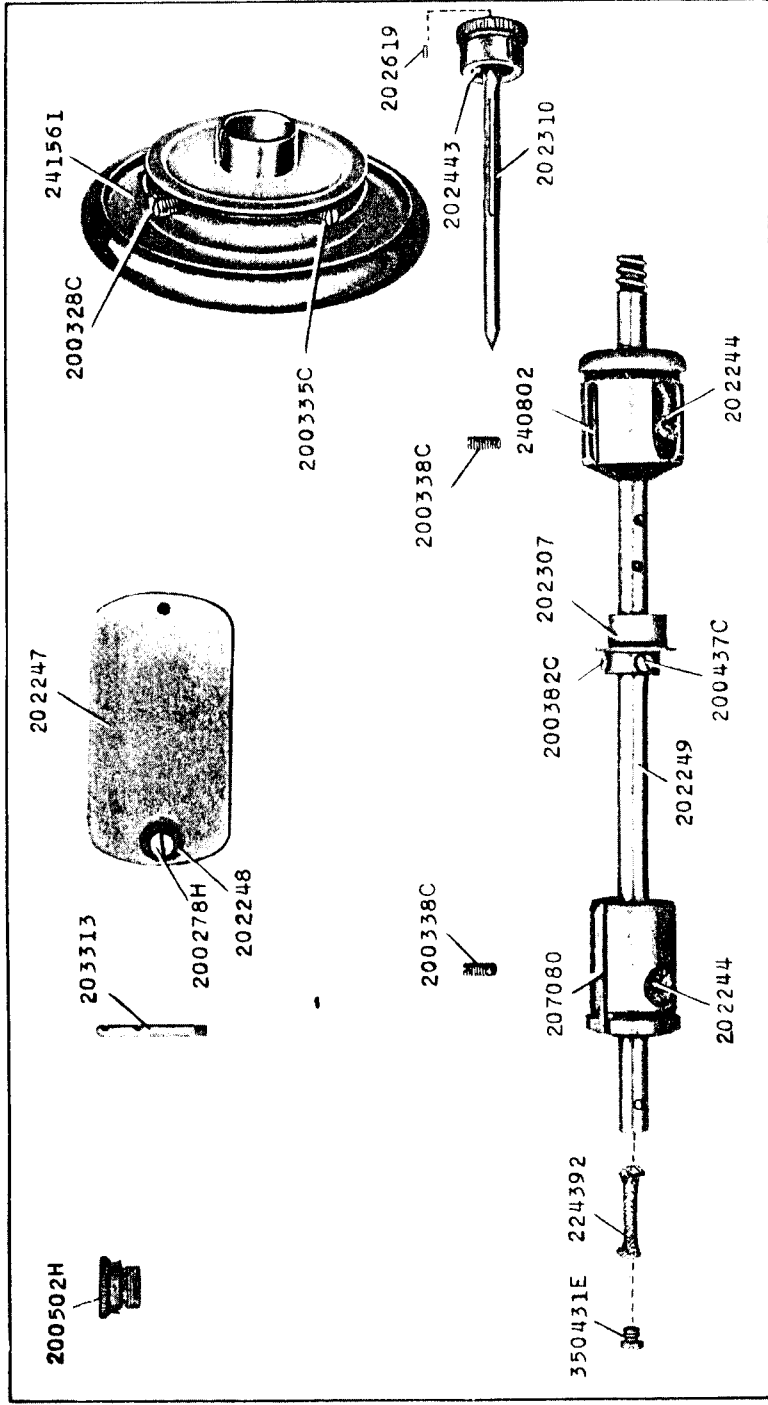

17673

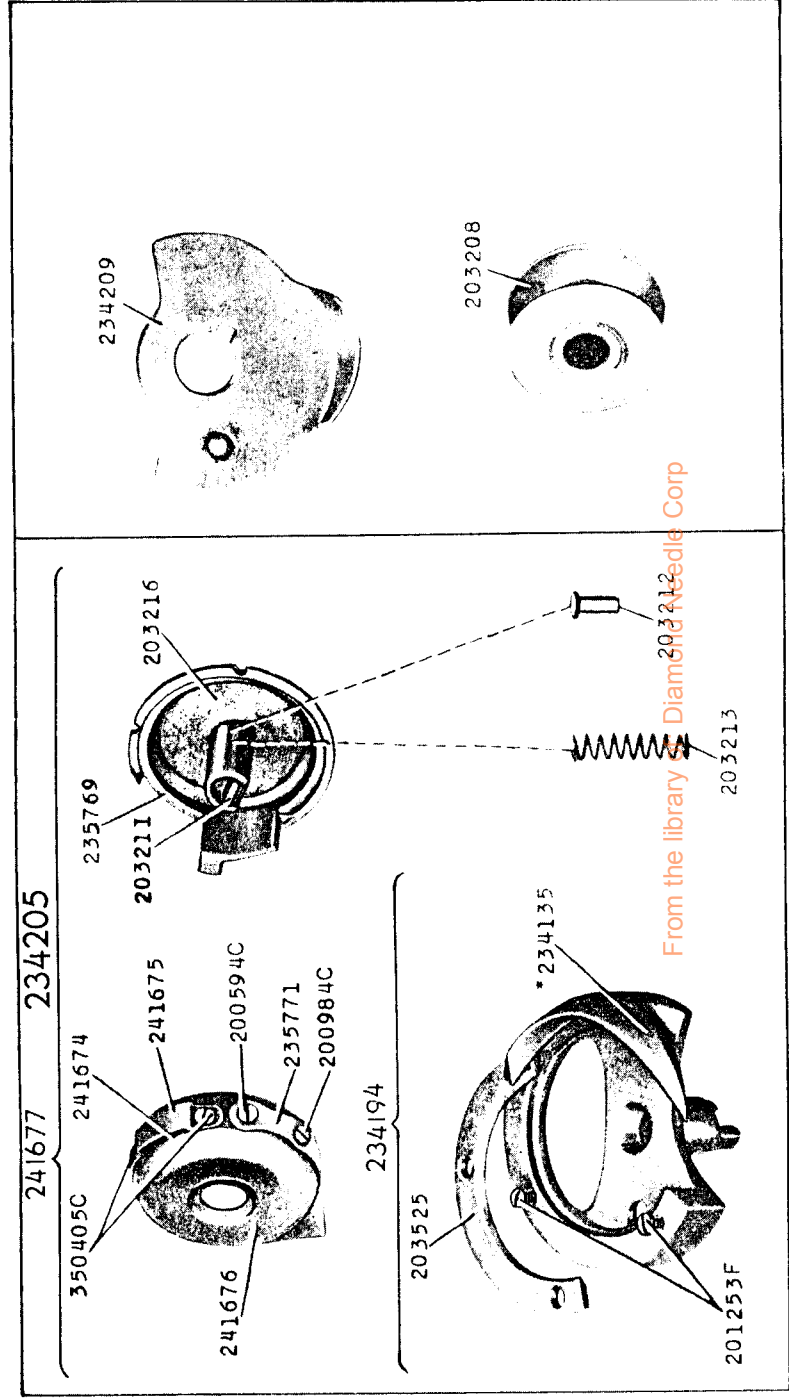

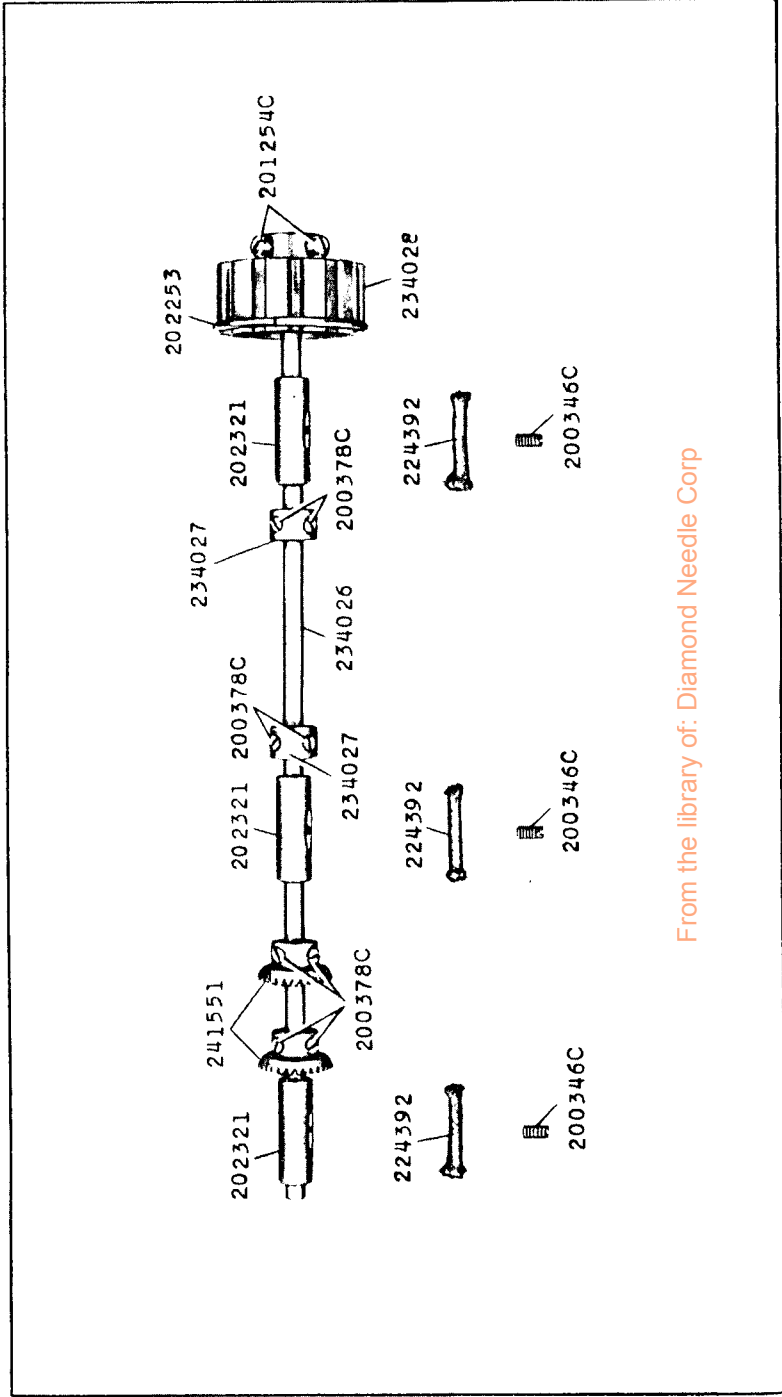
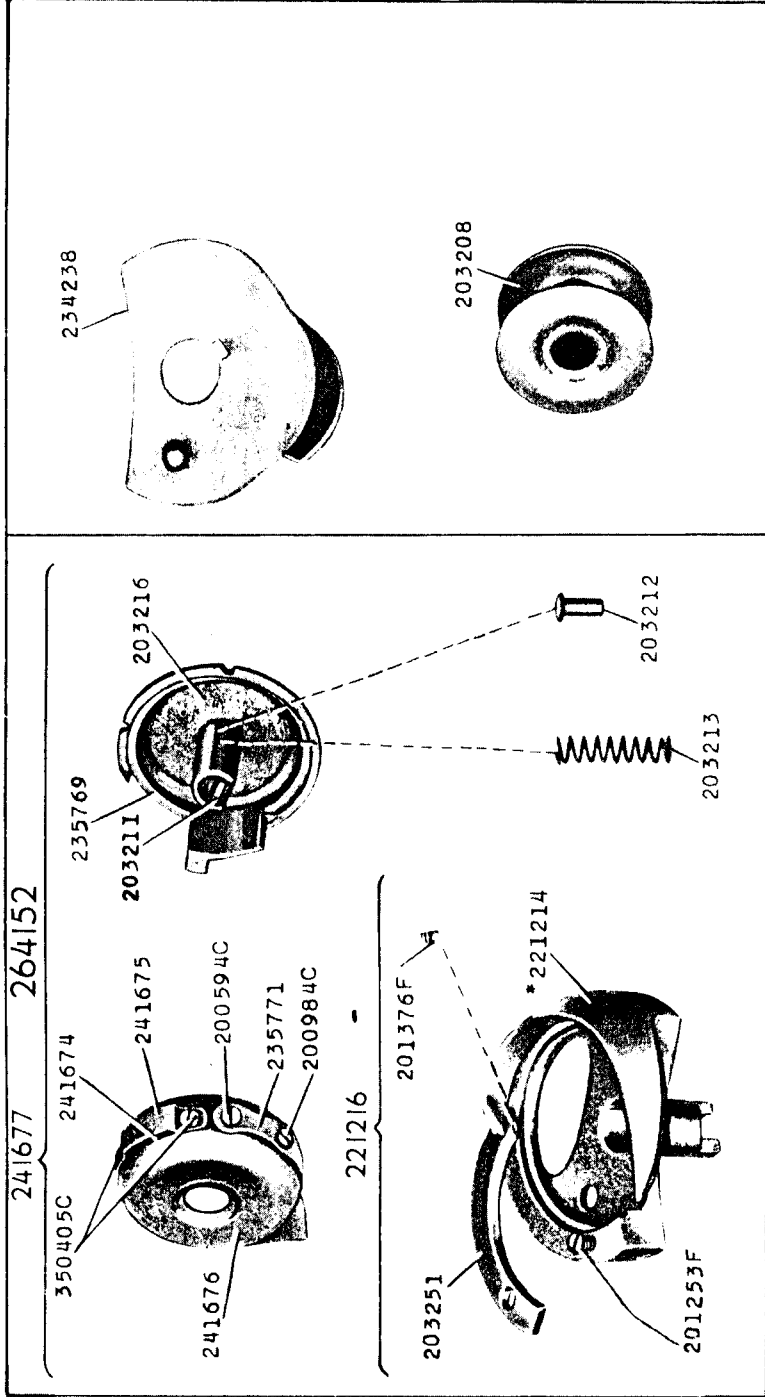

From the library of: Diamond Needle Corp







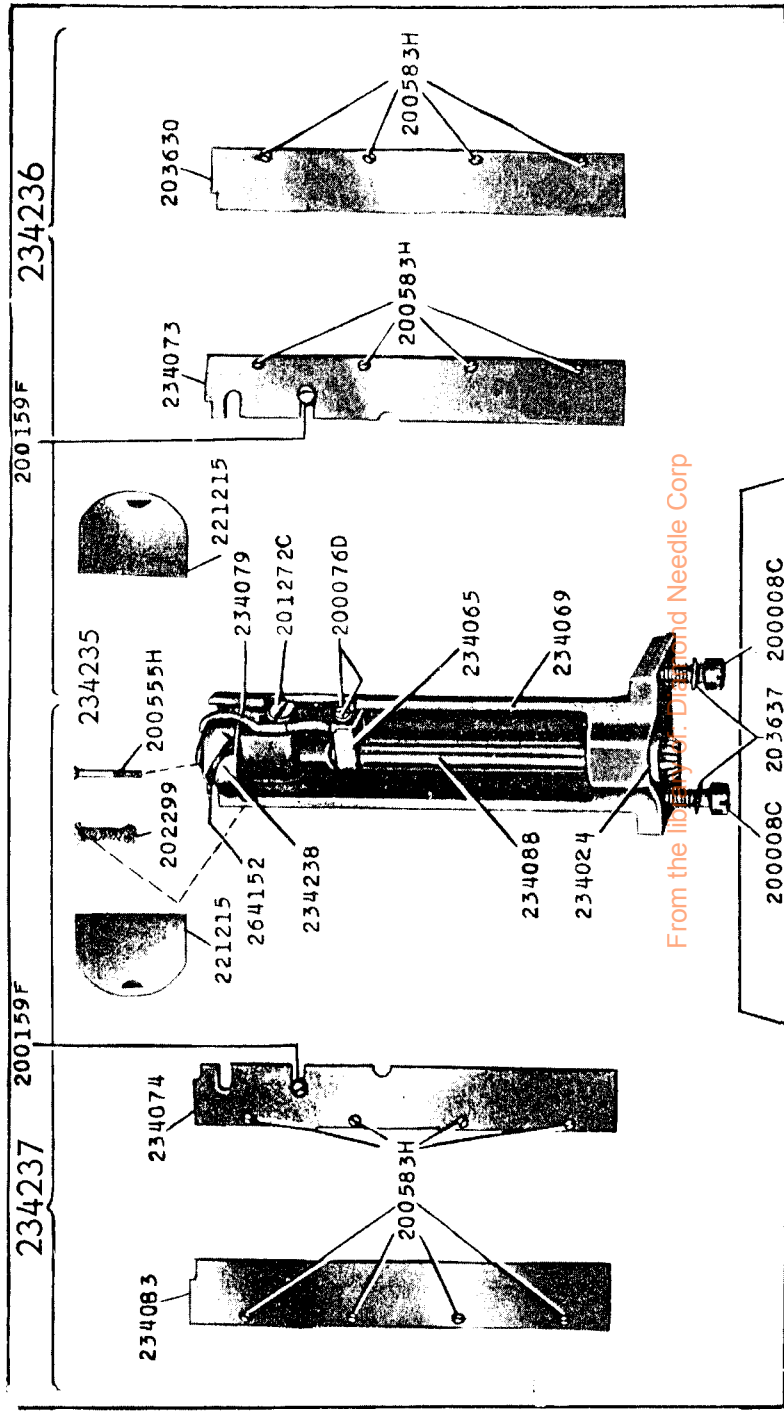
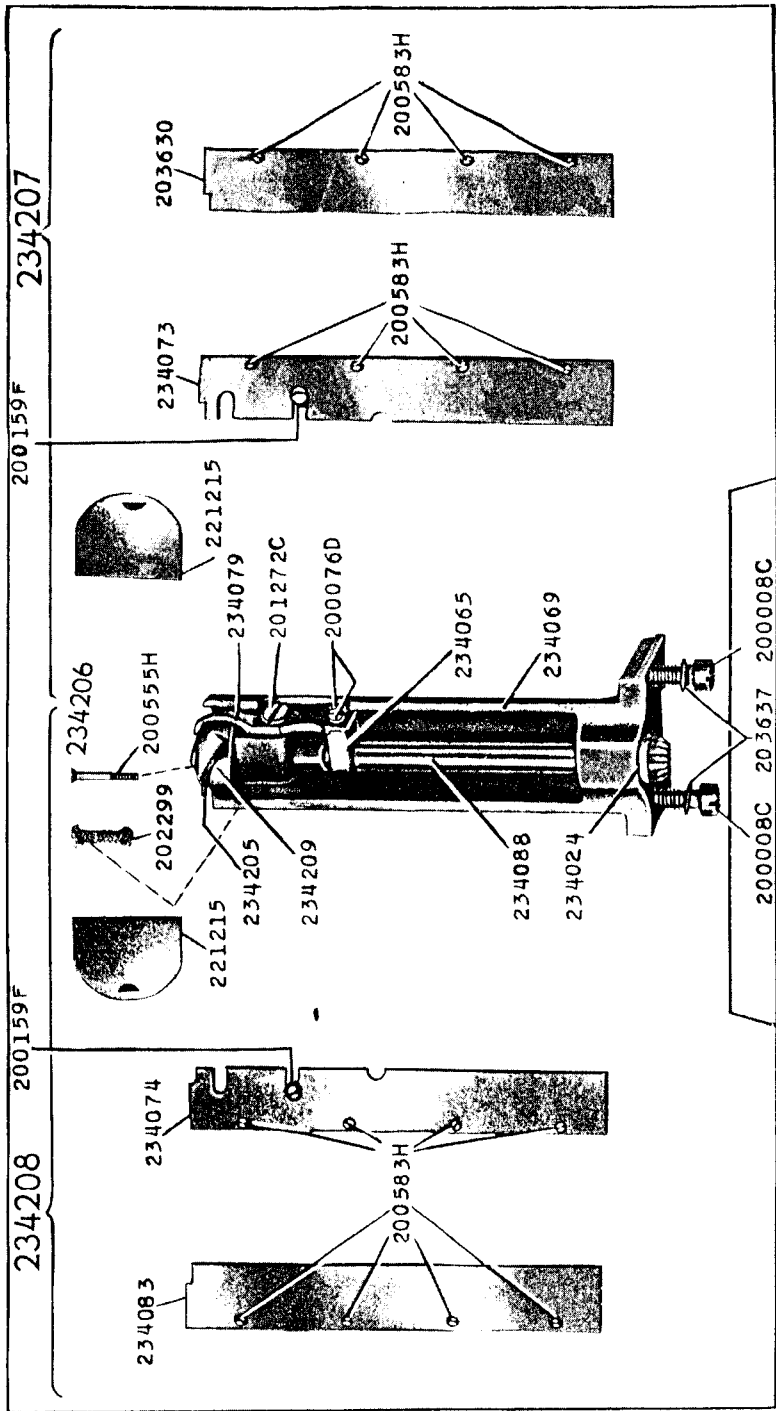

From the library of: Dispositif Needle Corp

